

Position Pickups for the Cryogenic Storage Ring

F. Laux, M. Grieser, R. von Hahn, T. Sieber, A. Wolf, K. Blaum
Max-Planck-Institut für Kernphysik, Heidelberg, Germany

Abstract

A cryogenic electrostatic storage ring (CSR) is under construction at the Max-Planck-Institut für Kernphysik in Heidelberg (MPI-K), which will be a unique facility for low velocity and in many cases also phase-space cooled ion beams. Amongst other experiments the cooling and storage of molecular ions in their rotational ground state is planned. To meet this demand the ring must provide a vacuum in the XHV range (10^{-13} mbar room temperature equivalent) which will be achieved by cooling the ion beam vacuum chambers to 2 - 10 K. This also provides a very low level of blackbody radiation. The projected beam current will be in the range of 1 nA - 1 μ A. The resulting low signal strengths together with the cold environment put strong demands on the amplifier electronics. We plan to make use of a resonant amplifying system. Using coils made from high purity copper, we expect quality factors of ~ 1000 . The mechanical design has to provide stability and reproducibility of the alignment despite thermal shrinking when switching from room temperature operation to cryogenic operation. A prototype pickup has been built in order to test resonant amplification and the mechanical design using the wire method. The resonant amplification principle was tested in the MPI-K's Test Storage Ring (TSR).

INTRODUCTION

The CSR will be a fully electrostatic storage ring used to store atomic and molecular ion beams [1]. The beam optics consist of quadrupoles, 6° deflectors to separate the ion beam from neutral reaction products and 39° deflectors. It will be possible to merge the ion beam with neutrals and a laser beam. The experimental straight sections contain an electron cooler and a reaction microscope for reaction dynamic investigations. One linear section is uniquely reserved for diagnostics which will contain quartz profile monitors, Schottky pickups, an ionization rest gas monitor, a sensitive squid based cryogenic current comparator and two beam position monitors [2].

For the cold supply a commercially available Linde 4.5 K helium liquefier is combined with an additional connection box assuring the adaption to the CSR's helium pipe system. To reduce blackbody radiation, a maximum temperature of 10 K of the inner vacuum chamber is required. Efficient pumping of hydrogen as the main rest gas component is necessary to reach a vacuum in the XHV range which will be achieved by cooling parts of the vacuum chamber down to 2 K. For commissioning of the ring the ability of room temperature operation is required and part of the cryogenics concept is the possibility of baking

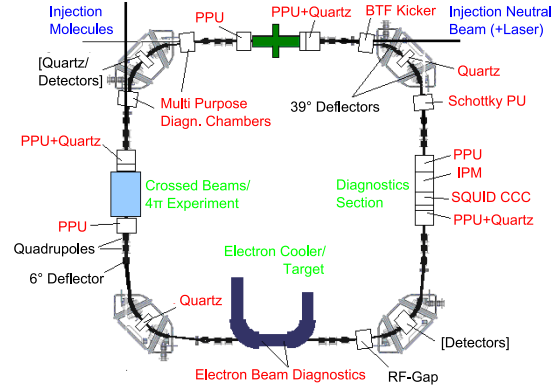

Figure 1: Overview over the CSR beam diagnostics system.

out the system to at least 300 °C. The cryogenic concept leading to the ability to reach vacua in the desired range was successfully tested with the Cryogenic Trap Facility (CTF) [3].

The extremely low temperatures, the large operational temperature range and the low pressures together with expected low signals are extremely challenging factors for the design of the storage ring components, particularly for the diagnostics equipment.

POSITION PICKUPS

Mechanical Design

In total six beam position monitors, each consisting of two pickups, are foreseen. One beam position monitor will be placed at each end of the diagnostics section as well as on both sides of the reaction microscope and of the third experimental section. The diagonal slit type linear pickups with a circular aperture will be used. The overall beam position monitor length will be ~ 35 cm and the diameter of the electrodes will be 10 cm.

The pickups themselves will be situated in a grounded shielding chamber which has two functions. Firstly, it shields the pickup plates from the cryo-pump, which is a panel made from metal and coated with charcoal to provide a large absorption area. This layer introduces extra electrical capacity and an implied unsymmetry into the system and it added up to the loss budget lowering the quality factor of the resonant circuit. Secondly, the shielding separates the actual signal from disturbing signals on the ground set up by the storage ring chambers. A provision of small holes in the chamber that shield against high frequency electric fields but improves pumping will be con-

sidered. The grounded shielding chamber is terminated by massive plates having an aperture of 10 cm, which is the smallest aperture in the beam pipe. These plates also serve as mounting points for the electrode struts. The grounded shielding chamber is placed on a cylindrical metal pillar, which is itself mounted on the 40 K shield. This cylinder must be thin-walled to prevent heat flux from the 40 K shield to the grounded shielding chamber. It will additionally be interrupted by a ceramic insert to electrically disconnect the grounded shielding chamber from the ring ground. Since the ring is supposed to be operated between 2 - 300 K, the height of the optical elements such as the quadrupoles will vary and the vertical position of the pickups must vary likewise. The capability of the pickups for absolute position determination is required to be 0.5 mm. The suspension of the optical elements will be made from glass fiber reinforced plastics and the pickup suspension must be composed of materials that compensate for the temperature shrinkage. The electrically and thermally floating pickup chamber has to be thermally connected to the experimental vacuum chamber by copper bands with sapphire inserts that ensure the electrical separation of the ring ground and the shielding chamber ground.

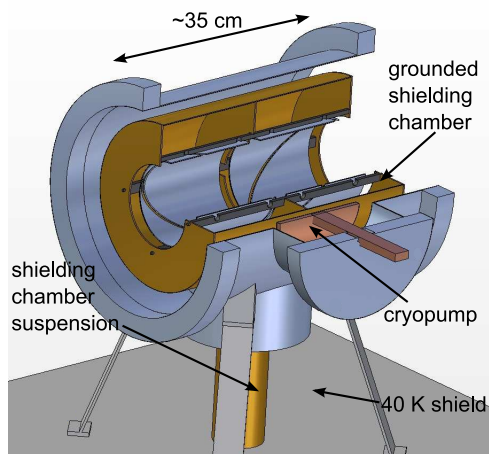

Figure 2: Preliminary mechanical design of the beam position monitor.

Amplification Principle

Table 1 summarizes some of the relevant beam parameters. The lower current limit derives from a minimum design current to operate the ring in connection with exotic large molecules with a low current source and in experiments with high reaction cross sections in which it will be necessary to lower the reaction rate to prevent from detector saturation.

For amplification of pickup signals in the kHz to MHz regime, originating from bunched beams with long bunch lengths, usually high impedance amplifiers with an input DC-resistance of 1 M Ω are used. This 'conventional' - non-resonant - method is planned to be used in the CSR

Table 1: Beam parameters

Mass range	1-100 amu
Energy range (1^+ ions)	20 - 300 keV
Frequency range	5 kHz - 200 kHz
Intensity range	1 nA - 1 μ A

as well. Additionally it is planned to extend the system with the possibility of resonant amplification which is, to first order, set up by an inductance supplementing the circuit in parallel with the combined capacity of the pickup electrodes, the signal feedthroughs and other extra capacities. At resonance the impedances of both the capacity and the inductance have the same absolute value but phase shifted by π and thus the impedance of the total circuit equals its purely resistive part. The large range of planned frequencies is set by the extended mass range of the stored ions. A resonant system which would cover the first harmonic frequency range would have to have an extremely large and variable capacity or inductance range, which is not feasible. Therefore a system with a frequency range from 200 kHz to 400 kHz is planned, so that e.g. a beam coasting at 5 kHz had to be bunched to its 40th harmonic. From the viewpoint of the coupling to the resonance circuit a narrow span of signal frequencies would allow optimal impedance matching to minimize noise transfer. In principle it is possible to bunch the beam to even higher harmonics to also move the signal frequency further away from the 1/f-noise regime. Additionally the manufacturing of the inductance for which we intend to use coils made from high purity copper became much simpler and the side effects of a high inductance coil such as self-capacity and wire resistance lowering the quality factor were of minor importance. There is, however, an upper limit for the harmonics with which the beam can be bunched, yet alone if the beam displacement is calculated from the pickup signal based on a calibration function obtained using a wire with an applied RF-frequency as a beam replacement. The EM wave generated by the wire has no component in the longitudinal direction and thus represents a TEM wave in the pickup and therefore a field of a beam with $\beta = 1$. As described by R. E. Shafer [4], for beams with $\beta \approx 1$ the difference signal divided by the sum, which is usually evaluated, if the beam displacement is determined, is frequency independent. There is, however, a dependence of the calibration curve on the frequency for low- β beams. Estimations using equations provided in [4] indicate that up to a harmonic number $h=40$ no low- β effects are expected. This number, together with the low frequency limit of a coasting beam, leads to the lower limit of the frequency range which must be covered by the resonant amplifying system. However, calculations of the low- β effects based on the finite elements method, are considered which include the special geometry of our pickup system, the result of which may shift the desired frequency range.

The tuning of the resonant circuit, that was used in test

measurements at the Test Storage Ring, was done with a tuning capacity, which is appropriate to withstand cryogenic temperatures and does not affect the quality factor of the resonant circuit. However its range of capacity change is not sufficient to tune the resonant circuit to frequencies in the desired range. As an alternative we will investigate piezo-element driven mechanic capacitors which have the advantage of a highly adjustable capacity range, but the disadvantage of slow variational speed.

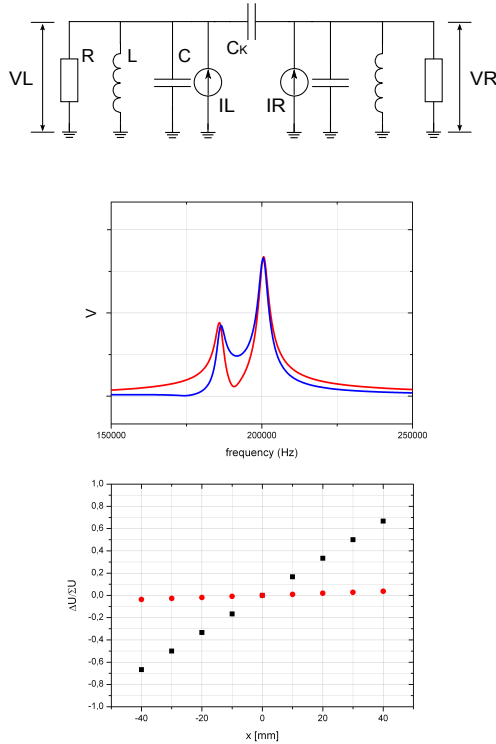

Figure 3: The effect of the coupling capacity on the resonant pickups. Upper plot: Equivalent circuit with the capacity of the pickup electrode (+cables etc.) and the coupling capacity C_k . The difference of the signal currents IL and IR is for a diagonally slit pickup linearly dependent on the beam displacement. For beam position measurements the left and right voltages VL and VR are processed. Middle: Frequency response with the resonant circuits tuned to 200 kHz and $C = 4$ pF. The curves (red: VR , blue: VL) are calculated for a beam position of $x = 30$ mm. Lower: Plot of the calibration curves. Black: Calibration curve for non-resonant amplification, i.e. without the inductances. The slope is decreased due to coupling with respect to the ideal case where $(VR - VL)/(VR + VL) = 1$ at $x = 50$ mm. Red: Calibration curve with resonant amplification. Its slope is decreased by a factor of 20 with respect to non-resonant amplification.

For the position measurement a simultaneous measurement of the signals from both pickup electrodes is preferable. Due to the large opposing areas of the pickup electrodes, there is always a considerably large coupling capacity present. Using non-resonant amplification, a high cou-

pling capacity lowers the displacement sensitivity, which can be partially improved using grounded guard rings that are inserted in the gaps between the electrodes. If resonant amplification of both electrodes is used, the presence of a capacity between the electrodes causes a coupling of the resonant circuits, resulting in a double resonance and a drastically reduced displacement sensitivity (Fig. 3).

A measurement system as depicted in Fig. 4 is currently planned to be used, with which the position will be measured stepwise. With relays, one electrode will be short cut to ground. By this the coupling capacity simply adds up to the capacity of the active electrode which is itself connected to the resonant amplifying system. In a second step the relays are switched to the other electrode. This method doubles the acquisition time with respect to a narrow band measurement in one step. The switching time of relays, which is typically <5 ms, must additionally be considered.

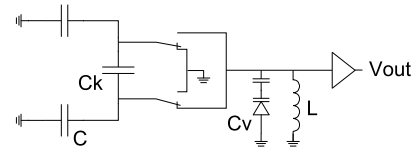

Figure 4: An amplification scheme using two relays and one tuning diode C_v .

OUTLOOK

A measurement with a copper coil at room temperature at the MPI-K's Test Storage Ring (TSR) has shown the expected increased signal by the quality factor of the resonance circuit. However, strong background signals from the RF-buncher of the TSR have significantly increased the uncertainty of the location measurement, in part because the background has unpredictable long term changes and at this time it was not possible to quickly switch between the electrodes. Changes of the amplifying system are currently underway which will reduce the background and allow for a quick electrode change to reduce measurement systematics.

REFERENCES

- [1] M. Froese et al., "Cryogenic ion beam storage", PAC 09 Proceedings, Vancouver, May 2009.
- [2] T. Sieber et al., "Beam diagnostics development for the Cryogenic Storage Ring CSR", WEPB23, DIPAC 07 Proceedings, Venice, May 2007.
- [3] M. Lange et al., "Commissioning of the Heidelberg Cryogenic Trap for Fast Ion Beams (CTF)", MOPC110, EPAC 07 Proceedings, Genoa, June 2008.
- [4] R. E. Shafer, "Beam position monitor sensitivity for low- β beams", Proc. Beam Instr. Workshop BIW, Santa Fe, 1994.